

# General Radio EXPERIMENTER

ELECTRICAL MEASUREMENTS AND THEIR INDUSTRIAL APPLICATIONS

## THE SERIES AND PARALLEL COMPONENTS OF IMPEDANCE

<i>Also</i>	
IN THIS ISSUE	
	<i>Page</i>
HEAT DISSIPATION FROM CABINETS.....	4
AN ENGINEERING APPROACH TO TROUT FISHING.....	5
ACKNOWLEDGMENT.....	7

● WE HAVE RECEIVED lately a number of inquiries about the meanings of such terms as "series capacitance," "parallel capacitance," "series resistance," "parallel resistance," etc., as they are used in instruction books for General Radio bridges. Although most engineers think in terms of the series components of impedance, many types of problems, particularly those involving vacuum tubes, are more

simply handled in terms of the parallel components. Certain bridge circuits give directly the series components of an impedance, while others can be arranged to give the parallel components, the choice depending on the intended application. Discussion of the relationship between the series and parallel components, however, seldom appears in the elementary textbooks.

That any impedance can be represented both ways is clear from the fact that measurements on it at a single frequency can determine only the relationship between the voltage across the impedance and the in-phase and quadrature components of the current flowing through it. Stated in terms of power engineering, a circuit element draws a certain amount of power at a particular value of power factor, and these two quantities completely define the effective impedance of the element for the conditions applying. It is sometimes convenient to represent the impedance as a pure resistance in series with a pure reactance, but it is very often more convenient to consider it as made up of a different value of resistance in parallel with a reactance.

FIGURE 1. Examples of equivalent series and parallel circuits.

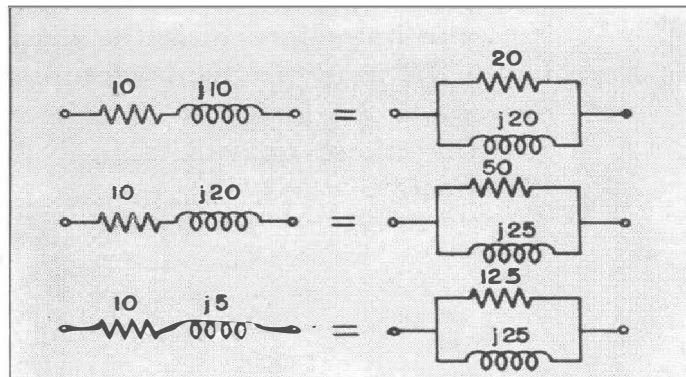

The two representations, however, are completely equivalent and either pair of components can be simply determined in terms of the other pair.

For example it will be seen that, in three cases shown in Figure 1, the first configuration of series elements would draw the same current, both in phase and magnitude as the second configuration, consisting of resistive and reactive elements in parallel. The two arrangements of each case are indistinguishable from each other by measurements made at their terminals at a fixed frequency.

The general relationship between the elements of the series and parallel arrangements can be simply found by equating the current drawn in the two cases.

$$i = \frac{e}{R_s + jX_s} = \frac{e}{R_p} + \frac{e}{jX_p} \quad (1)$$

where  $R_s$  and  $X_s$  are the series components and  $R_p$  and  $X_p$  are the parallel components. Rationalizing and equating the real and imaginary terms,

$$\frac{R_s}{R_s^2 + X_s^2} = \frac{1}{R_p}$$

or

$$R_p = R_s \left( 1 + \frac{X_s^2}{R_s^2} \right) \quad (2)$$

$$\frac{X_s}{R_s^2 + X_s^2} = \frac{1}{X_p}$$

or

$$X_p = X_s \left( 1 + \frac{R_s^2}{X_s^2} \right) \quad (3)$$

The quantity  $X_s/R_s$  is the familiar  $Q$  or storage factor of an inductor or capacitor, and its reciprocal is the dissipation factor  $D$ , more frequently employed in describing the losses in capacitors. Substituting these quantities in Equations (2) and (3),

$$R_p = R_s (1 + Q^2) = R_s \left( 1 + \frac{1}{D^2} \right) \quad (4)$$

$$X_p = X_s \left( 1 + \frac{1}{Q^2} \right) = X_s (1 + D^2) \quad (5)$$

These equations give the parallel components of impedance directly in terms of the series components. The relationships, however, serve equally well when the series components are required and the parallel components are given, because the quantity  $Q$  or  $D$  can be determined directly from either the series or parallel components. Dividing (4) by (5),

$$\frac{R_p}{X_p} = \frac{R_s}{X_s} Q^2 = \frac{R_s}{X_s} \frac{1}{D^2}$$

or

$$Q = \frac{1}{D} = \frac{X_s}{R_s} = \frac{R_p}{X_p} \quad (6)$$

so that  $Q$  can be determined immediately, whichever components are given, and used in Equations (4) and (5) to obtain the other components. A further simplification is that only one of the two Equations (4) and (5) need be employed with (6) to make the complete transformation. The three steps in each case are as follows:

*Given  $R_s$  and  $X_s$*

$$(1) \quad Q = \frac{X_s}{R_s}$$

$$(2) \quad R_p = R_s (1 + Q^2)$$

$$(3) \quad X_p = \frac{R_p}{Q}$$

*Given  $R_p$  and  $X_p$*

$$(1) \quad Q = \frac{R_p}{X_p}$$

$$(2) \quad R_s = \frac{R_p}{1 + Q^2}$$

$$(3) \quad X_s = R_s Q$$

If it is preferred to work in terms of dissipation factor the corresponding



steps are:

Given  $R_s$  and  $X_s$

$$(1) D = \frac{R_s}{X_s}$$

$$(2) R_p = R_s \left( 1 + \frac{1}{D^2} \right)$$

$$(3) X_p = R_p D$$

Given  $R_p$  and  $X_p$

$$(1) D = \frac{X_p}{R_p}$$

$$(2) R_s = \frac{R_p}{1 + \frac{1}{D^2}}$$

$$(3) X_s = \frac{R_s}{D}$$

It is seen that use of  $Q$  or  $D$ , which are associated with equal simplicity with either the series or parallel components, greatly facilitates the transformation. Since (6) is readily borne in mind, the only relation that need be remembered is that, as seen from (4), the ratio between the parallel and series resistances is the quantity  $1 + Q^2$ . It should be noted that the parallel resistance and parallel reactance are always greater than the corresponding series components. It is obvious that for large  $Q$  the series resistance must be small compared with the series reactance, but the parallel resistance must be large compared with the parallel reactance.

One of the simplest examples of the utility of the parallel impedance components is in parallel resonant circuits where the coil losses are high. It will be seen in Figure 2 that parallel resonance

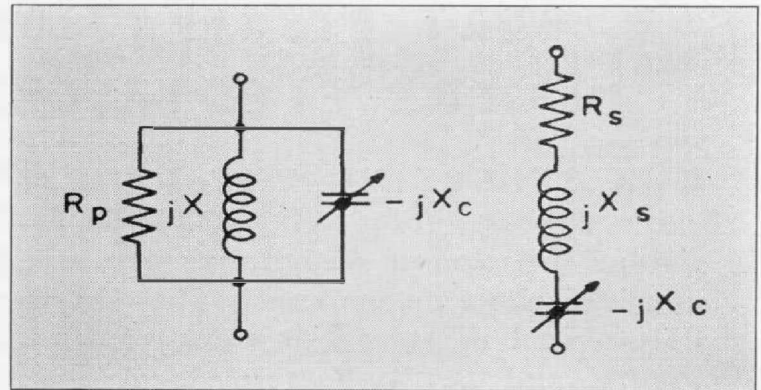

FIGURE 2. Series and parallel resonant circuits. The capacitance necessary to resonate with a given inductance will depend upon whether the elements are connected in series or in parallel.

occurs when the condenser reactance is exactly equal to the parallel reactance of the inductor, regardless of the coil losses. If the tuning capacitance for parallel resonance is determined from the series components of the coil impedance, on the other hand, the required value depends both on the resistance and on the reactance. In the series circuit the opposite applies and resonance occurs when the condenser reactance is exactly equal to the series reactance of the inductor. Where the  $Q$  of the coil is high, the difference between its series and parallel reactance is negligible in ordinary applications. Even with a  $Q$  of 10 the difference is only one per cent. But for lower values of  $Q$  the difference rapidly increases. The parallel reactance of an inductor with a  $Q$  of 1 is twice the series reactance, so that only half the capacitance is required to tune it to resonance in a parallel circuit as in a series circuit.

— W. N. TUTTLE



## HEAT DISSIPATION FROM CABINETS FOR ELECTRICAL INSTRUMENTS

● IN SELECTING THE TYPE of cabinet construction to be used in a particular instrument design, performance considerations are generally thought to dictate such matters as shielding requirements and anti-vibration treatment, whereas the importance of aesthetic appeal, portability, compactness and cost is evaluated in terms of customer demand. The fact that practically all instruments, at least those using vacuum tubes, dissipate a certain amount of heat is not only a design problem that is often neglected in the first draft of an instrument, but may be the limitation on both the quality of shielding, if ventilation is necessary, and the minimum practical size to which a unit can be built. Taking account of the heating immediately raises the problems of what is an allowable maximum operating temperature, and how to predict the dissipation capacity of a cabinet of given construction and size.

Although the highest ambient temperature expected in the field of application generally determines the criterion for temperature rise, the hot spot temperature is the limiting factor where the deterioration of components is concerned, and the average temperature rise is restricted by precise circuit elements when temperature coefficients obtain. Taking 50° C (122° F) as the maximum ambient at which a laboratory instrument is likely to be used, we find that for most circuits a 40° C rise for the hot spot and a 20° C rise for the maximum air temperature give conservative operating conditions.

Not only are the thermal conditions existing in even an idealized cabinet so

complicated as to defy analysis, but they are widely different from those met in an actual instrument, so that the exact physical analysis, if it were available, would be impractical to apply to a specific design. A general understanding of the physical phenomena involved is, however, helpful in suggesting methods of improving the heat dissipation of a cabinet.

If we examine the three possible methods for heat to escape from an unventilated box containing the usual complement of vacuum tubes and transformers, it becomes evident that conduction accounts for most of the heat loss and that convection and radiation are small factors, because of the low temperatures of the walls. Heat coming from the air inside must have a temperature drop to push it through the cabinet wall as well as through the air films immediately inside and outside of the wall. The resistance to heat flow of a metal wall is negligible in comparison to that of these air films, although a thick wood or fabric covered wood wall has a resistance comparable to that of one of the air films. An appreciable proportion of the heat is usually generated at high temperatures, and its transfer to the inside surface of the case is therefore by radiation, so that the more closely the inside of the case resembles a black body the better will it be. In spite of the fact that the absorption of radiant energy raises the temperature of the inside surface of the case and thus reduces the temperature difference that drives the heat through the inside air film, the net effect is to increase the heat flow by raising the outside surface temperature.



Even at the low temperatures that are satisfactory for the outside surface of a cabinet, a small gain in heat dissipation results from improving the radiation efficiency of the outside surface. In short, a metal case with dull black finish inside and outside is the most efficient for this class of electrical equipment.

Experimental evidence indicates that in cabinets of 100 square inches or larger the heat dissipation capacity at a given temperature is proportional to the area. The following table shows clearly the effect mentioned above of the various finishes and materials used in conventional cabinet construction, and these data give a means of making sufficiently accurate calculations to be useful as a design tool provided wide departures from the average conditions stated are not encountered.

Panels metal and vertical.

Heat sources distributed.

Maximum air temperature rise =  
20° C

Maximum hot spot temperature rise  
= 40° C

$$P = kA$$

$P$  = Allowable power dissipation,  
watts.

$k$  = Empirical constant,  
watts/square inch.

$A$  = Area, square inches.

Type of Construction	$k$
Aluminum, panel and box unfinished.	0.04
Aluminum, outside of panel and inside and outside of box painted black.	0.08
Airplane Luggage, $\frac{3}{8}$ " thick plywood, black fabric lined and covered.	0.05
Airplane Luggage, $\frac{3}{8}$ " thick plywood, 0.005" copper lined, black fabric covered.	0.04
Airplane Luggage, $\frac{3}{8}$ " thick plywood, 0.005" copper lined, lining painted black, black fabric covered.	0.05
Walnut, $\frac{1}{2}$ " thick.	0.05
Walnut, $\frac{1}{2}$ " thick, 0.005" copper lined.	0.03
Walnut, $\frac{1}{2}$ " thick, 0.005" copper lined, lining painted black.	0.06
Relay Rack, outside of panel painted black, box nickel plated.	0.04
Relay Rack, outside of panel and inside of box painted black, outside of box nickel plated.	0.05
Relay Rack, outside of panel, and inside and outside of box painted black.	0.07

The design engineer is generally confronted with one of two problems, either the size of a unit is fixed, and the question is whether ventilation will be required or not, or the size is not yet determined, and a decision must be made as to whether the physical size of the circuit components or the heat dissipation capacity of the cabinet will limit the minimum size. The empirical method will invariably be used to determine the final solution to these problems, but much effort can be saved by a preliminary calculation.

— H. C. LITTLEJOHN

## AN ENGINEERING APPROACH TO TROUT FISHING

● UNDER THE TITLE "Busman's Holiday" we mentioned in our September, 1945, issue the measurements made by Mr. Robert F. Field of the General Radio engineering staff on water depth and temperature in Lake Winnepesau-

kee. Apparently there are a few engineers who like to spend their leisure hours in the highly optimistic pursuit known as angling, and some interest has been expressed by them in a more detailed statement of Mr. Field's investigation.

The project had two underlying motives, one economic, the other scientific. From the economic viewpoint it was desirable to find where the trout were in summer in order to increase the protein content of the family food supply; the scientific objective was to establish a relationship between water depth and temperature, and to find the deepest spot in the lake. Both objectives, we are happy to report, were attained.

That excellent fish, the lake trout, abhors warm water. Consequently, when summer comes and the water at the lake surface and in shallow areas reaches temperatures of 70 to 80 degrees Fahrenheit, he beats a hasty retreat to the deep water, where more comfortable temperatures can be found. At any lake, the old timers eagerly point out where the deep spots are located. Unfortunately, their stories seldom agree closely enough to permit the fisherman to troll through the exact spot and pull in the trout. At times, the stories follow a pattern and are obviously folklore. At others, a comparison of data from different sources produces more than a suspicion of organized conspiracy to suppress the true facts. An objective investigation, however, will invariably settle the matter.

The necessary equipment consisted of

a boat, a minimum-reading thermometer and a line marked at 10-foot intervals.

In the accompanying plot are shown the results of the investigation. For the first 30 feet of depth, the temperature depends upon the time of day and upon such factors as the weather for the previous several days. The two upper curves show the difference between late afternoon and the following morning, and the lowest curve is the result of several days of cool, rainy weather. Below these surface differences, the ultimate depth does not affect the temperature-depth relationship until a 40-foot depth is reached. At greater depths, the data follow two well-defined curves. The upper curve is for ultimate depths of about 100 feet or less and a minimum temperature of about 50 degrees. When the ultimate depth is around 150 feet, the temperature below 90 feet drops to 41 degrees and stays constant thereafter. The 41-degree water is where the lake trout are found. This temperature is close to the theoretical value of 39.2 degrees where water has its maximum density.

From the plot, it is evident that, if the temperature readings fall along the upper curve, no 41-degree water (and no trout) will be found at that spot. If the readings follow the lower curve, how-

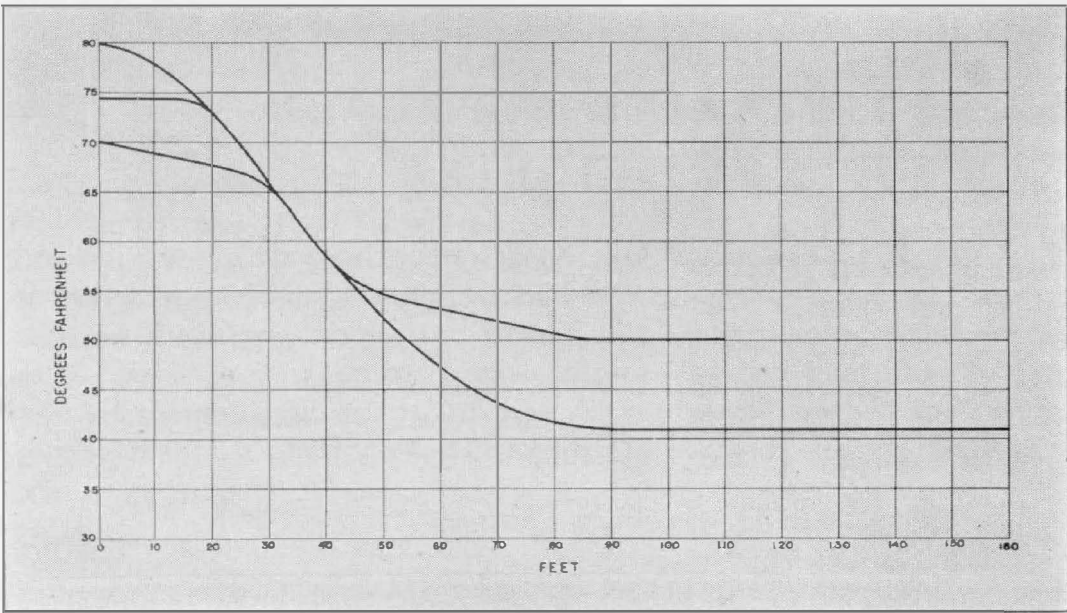

Temperature of water as a function of depth. Near the surface, the temperature depends upon the time of day and the weather for the preceding several hours, and the three branches of the curve illustrate the differences encountered. At depths below about 40 feet the curve has two branches, one for ultimate depths of about 100 feet, the other for ultimate depths of 160 feet or more.



ever, a deep area at depths up to 150 feet or more is indicated. It should be noted that 41-degree water is possible at ultimate depths less than 150 feet if the spot is spring fed. From the fisherman's viewpoint, this is quite satisfactory, since temperature, rather than depth, is

his primary concern.

In summary, it can be said that the results were eminently satisfactory. In the deep spots located, lake trout were plentiful, and a 159-foot depth was determined to be the maximum in that part of the lake covered by the survey.

## ACKNOWLEDGMENT

● **DURING THE WAR** the load on the American industrial machine was enormous — but it didn't break down; it delivered about what was expected of it. In our own small corner of industry we were no exception. The requirements of our Armed Services and of our Allies for our regular catalog products grew beyond anything that had ever been estimated, and kept right on growing. On top of this we were called upon to produce to government specifications large numbers of complicated and still classified measuring equipment which was as precise as the best laboratory types.

We regularly manufacture a variety of test equipment and precision components with almost two hundred different type listings in our present catalog. Most of these products are made in relatively small quantities even under wartime conditions, but they generally are important production tools or components of other electronic equipment; thus the demand was most urgent. We were uniquely in a position to build some of them, having the facilities, the machines, the skilled manpower (although badly reduced by the draft), and the requisite engineering experience.

To permit concentration of all our effort upon the making of these products

we released, on our own initiative, complete drawings and all technical information in our possession for a great many of our other products to other manufacturers who took on the task of making them under their own separate contracts with the Government to help fill the urgent war needs of the moment.

In most cases the new manufacturers took hold and did an outstanding production job. In some instances they had little previous experience with this class of manufacture which makes their achievement even more impressive.

There was and is no connection between these organizations and the General Radio Company, not even to the extent of royalty payments. We delivered the manufacturing and engineering details at no charge and collected no royalties — the only considerations were that the production be for direct war purposes and that the manufacture would cease at the end of the war emergency.

In many ways these contacts were a pleasant and useful experience for us. We got to know better many members of our own and allied industries and we discovered, by attempting to explain them, some of the weaknesses in our own designs which has helped us with new designs.



Among the companies with whom we worked and our products with which they were concerned are:

- Automatic Signal Corp., So. Norwalk, Conn. . . . . TYPE 572-B Microphone Hummer
- W. W. Boes Company, Dayton, Ohio . . . . . TYPE 583-A Output Power Meter  
TYPE 578-B Shielded Transformer
- Bond-Halstead, Inc., Wilmington, Delaware . . . . . TYPE 380-P3 Switch
- Eastern Company, Cambridge, Massachusetts . . . . . TYPE 487-A Megohmmeter
- Hugh H. Eby, Inc., Philadelphia, Pennsylvania . . . . . Terminals
- Federal Manufacturing & Engineering Company,  
Brooklyn, New York . . . . . TYPE 804-C Standard-Signal Generator  
TYPE 605-B Standard-Signal Generator
- Florida Aircraft Company, Fort Lauderdale, Florida . . . . . TYPE 774 Plugs and Patch Cords
- Freed Radio Corporation, New York City . . . . . TYPE 568 Condenser
- General Communications Company, Boston, Mass. . . . . TYPE 834-B Electronic Frequency Meter  
TYPE P-496 Electronic Frequency Meter
- M and Z Industrial Development Co., Bayonne, N. J. . . . . TYPE 434-B Audio-Frequency Meter
- The Muter Company, Chicago, Illinois . . . . . TYPES 214, 314, 371, 471 and 433  
Rheostat-Potentiometers
- National Electrical Machine Shops, Washington, D. C. . . . . TYPE 774-YB Terminal Units
- Frank Reiber, Inc., Los Angeles, California . . . . . TYPE 804-C U-H-F Signal Generator
- Stoddart Aircraft Radio Company, Los Angeles, Cal. . . . . TYPE 714-A Amplifier  
TYPE 672-A Power Supply  
TYPE 673-A Power Supply
- Ucinite Company, Newtonville, Massachusetts . . . . . Plugs and Dials

**GENERAL RADIO COMPANY**

275 MASSACHUSETTS AVENUE

CAMBRIDGE 39

MASSACHUSETTS

TELEPHONE: TROWBRIDGE 4400

**BRANCH ENGINEERING OFFICES**

NEW YORK 6, NEW YORK  
90 WEST STREET  
TEL.—WORTH 2-5837



CHICAGO 5, ILLINOIS  
920 SOUTH MICHIGAN AVENUE  
TEL.—WABASH 3820

LOS ANGELES 38, CALIFORNIA  
1000 NORTH SEWARD STREET  
TEL.—HOLLYWOOD 6321

